



About the Tournament

The University of Texas Women's Ultimate program and Without Limits are proud to host the ninth annual women's division of College Centex.

This is our fourth year of partnership together, and every year, this tournament reminds us of how important our friends are to the success of our work. In 2008, over 30 college leaders gathered in the parking lot of the IM Fields and talked about the need for change in the college women's division. The following year, we resolved to take positive steps toward the change we had all discussed, and we haven't looked back since. Thank you for joining us on this journey, and for coming back to support this tournament year after year. The future of college women's ultimate is bright because of players and teams like you. Thank you for all of your love and support. It is much appreciated.

Our Vision

1. Competition- We are dedicated to bringing teams the best competition possible at Women's College Centex.
2. Community- We love our friends in the women's ultimate community, and we run this tournament for YOU.

Thank you for choosing to support our tournament.
Play hard, play fair, and have fun!

Emergency Contact

Michelle Ng | (415) 215-0903



Tournament Rules

USA Ultimate 11th Edition Rules

For games to 13: point cap at 15

For games to 15: point cap at 17

HORNS

Due to the split field site and the poor acoustics of the field site, we will not be blowing cap horns. Please communicate with the opposing teams' captains about cap times.

TIMEOUTS

One timeout per half plus one floater. Caps do not affect timeouts.

CAPS

Soft cap: Add two to the higher score after the point and play to that. No more win by 2.

Hard cap: Finish the point. If it's tied, play one more. If not, game over.

DETERMINING POOL FINISHES IN CASE OF A 3-WAY TIE

Results will be determined using:

1. Point differential among teams in the tie
2. Point differential against the rest of the pool
3. Total points scored
4. Coin flip

WOMEN'S COLLEGE CENTEX 2012

SATURDAY SCHEDULE

All Divisions Friday, March 23

Without Limits Throwing Mixer (IM Fields)	7:00-8:30
Women's College Centex Fundraiser (Yogurt Planet)	8:30-9:30

Divisions I and II (IM Fields) Saturday, March 24

	Captains' Meeting	10:30		
	Start Time	Soft Cap	Hard Cap	
Pool Play Round 1	11:00	12:30	12:50	
Pool Play Round 2	1:00	2:30	2:50	
Pool Play Round 3	3:00	4:30	4:50	
Re-Seed				

After re-seeding, Top 4 teams in Division III will play crossover games at IM Fields. Division I and II teams will also play crossovers at the IM Fields.

Division III (Northeast Metro) Saturday, March 24

	Captains' Meetings	8:15 and 10:15		
	Start Time	Soft Cap	Hard Cap	
Pool Play Round 1	8:45	10:15	10:35	
Pool Play Round 2	10:45	12:15	12:35	
Pool Play Round 3	12:45	2:15	2:35	
Re-Seed Pools J and K				
Pool Play Round 4 / Crossover Round	2:45	4:15	4:35	
Re-Seed Pool I				

All Divisions (IM Fields) Saturday, March 24

	Start Time	Soft Cap	Hard Cap
DI / DII and DII / DIII Crossovers	5:30	7:00	7:20
BBQ Dinner		6:00-8:00	
Dance-Off		8:00-9:00	
Social (Black Sheep Lodge)		9:00	

WOMEN'S COLLEGE CENTEX 2012 SUNDAY SCHEDULE

Divisions I and II (IM Fields) Sunday, March 27

	Start Time	Soft Cap	Hard Cap
Bracket Play Round 2	8:15	9:30	9:50
Bracket Play Round 3	10:00	11:15	11:35
Bracket Play Round 4	11:45	1:00	1:20
Bracket Play Round 5	1:30	2:45	3:05
Championship Game	2:15	3:45	4:05
Bracket Play Round 6	3:15	4:30	4:50

Division III (Northeast Metro) Sunday, March 27

	Start Time	Soft Cap	Hard Cap
Bracket Play Round 2	8:15	9:30	9:50
Bracket Play Round 3	10:00	11:15	11:35
Bracket Play Round 4	11:45	1:00	1:20
Bracket Play Round 5	1:30	2:45	3:05

Consolation Bracket and Pool Play (Northeast Metro) Sunday, March 27

	Start Time	Soft Cap	Hard Cap
Round 2	8:15	9:30	9:50
Round 3	10:00	11:15	11:35
Round 4	11:45	1:00	1:20
Round 5	1:30	2:45	3:05

WOMEN'S COLLEGE CENTEX 2012 INSTRUCTIONS FOR REPORTING SCORES

Please report your scores via text message to (415) 215-0903. At the end of the day, check to make sure that your scores are reported at Frisbee Central. You may also report your scores via the USAU SRT.

ALSO, as a USAU Competitive Premier Sanctioned Event, we are responsible for collecting spirit scores for each game. Please include this when you text your score.

Example

Your Team: University of California-Santa Barbara Burning Skirts

Opponent: University of Washington Element

Final Score: 15-11

Spirit Score for Your Opponent: 5

TEXT:

Santa Barbara 15 - Washington 11 (F); SS = 5

Please keep in mind that we are collecting scores for 42 teams, so use team names that are clear.

TEXT SCORES TO (415) 215-0903.



QR code for reporting scores via SRT



WithoutLimitsUltimate



@wultimate

WOMEN'S COLLEGE CENTEX 2012 ADDRESSES AND OTHER INFORMATION

FRIDAY NIGHT EVENTS

Without Limits Throwing Mixer

ADDRESS

University of Texas IM Fields
51st St and Guadalupe St
Austin, TX 78751

Come out to the fields for free food and a chance to hang out with players from around North America. Throw, play some disc games, trade jerseys, and enjoy a relaxing evening before the weekend starts in full force.

Yogurt Planet Fundraiser

ADDRESS

Yogurt Planet
4601 North Lamar Blvd
Austin, TX 78751

After the throwing mixer, we'll head over to Yogurt Planet (across the street), one of our sponsors, for froyo and fun!

SATURDAY NIGHT EVENTS

BBQ and Dance-Off

ADDRESS

University of Texas IM Fields
51st St and Guadalupe St
Austin, TX 78751

Players from all three divisions will gather for a BBQ dinner and the famed Centex Dance-Off.

Social

ADDRESS

Black Sheep Lodge
2108 S Lamar Blvd
Austin, TX 78704

This local eatery is one of our favorites and is owned by a member of the Austin ultimate community. Come hang out starting at 9 PM!

Field / Hospital Information

IMPORTANT ADDRESSES

Division I / II Field Site
University of Texas IM Fields
51st St and Guadalupe St
Austin, TX 78751

Division III Field Site
Northeast Metro Park
2703 E Pecan Street
Pflugerville, TX 78660

Seton Medical Center
1201 W 38th St
Austin, TX 78705
(512) 324-1000

Seton Pflugerville Healthcare Center
200 Heatherwilde Blvd
Pflugerville, TX 78660
(512) 324-5350

WOMEN'S COLLEGE CENTEX 2012 FIELD MAP- UT INTRAMURAL FIELDS

GUADALUPE STREET

PARKING

PARKING

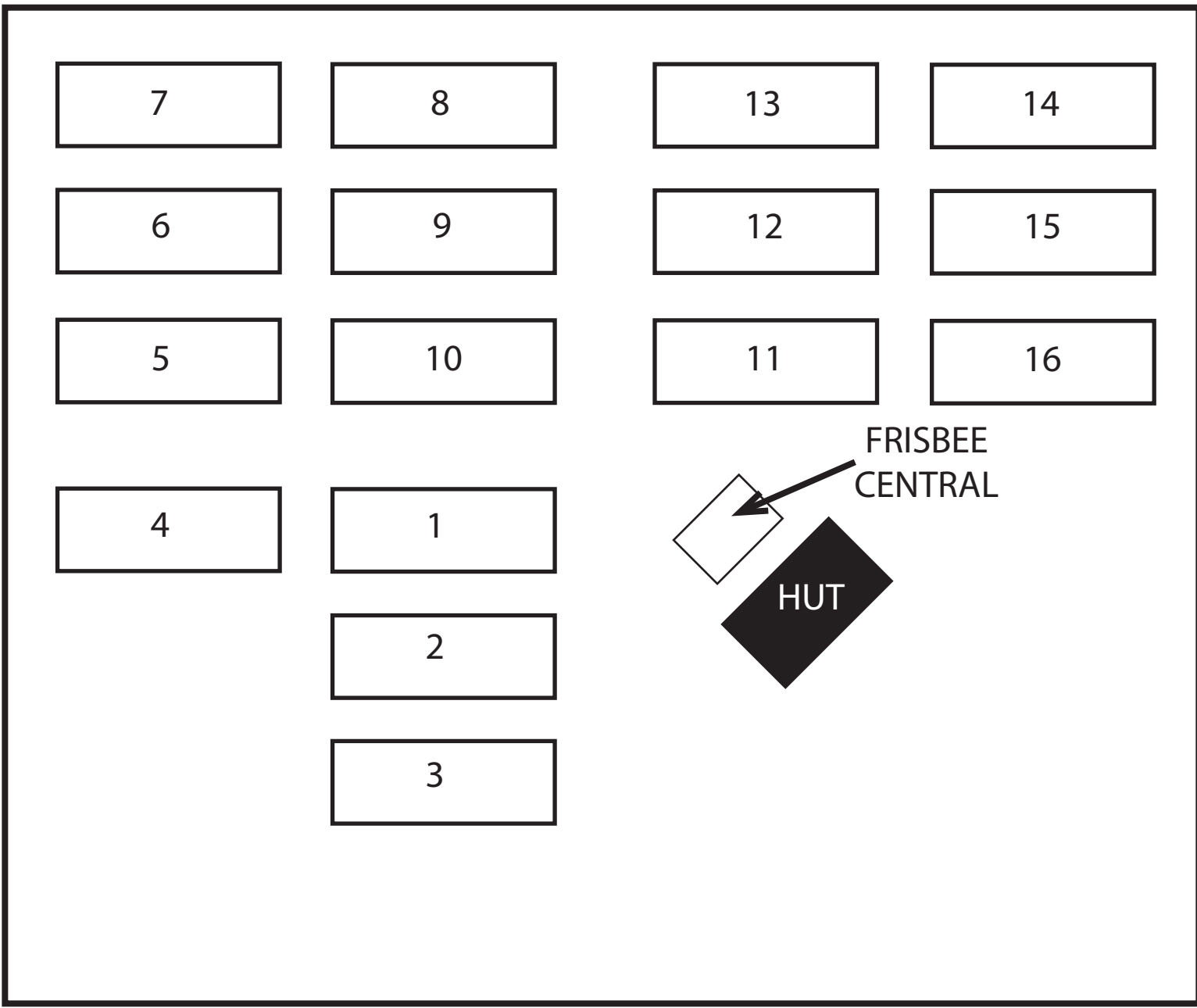

WOMEN'S COLLEGE CENTEX 2012 FIELD MAP- NORTHEAST METRO PARK (PFLUGERVILLE)

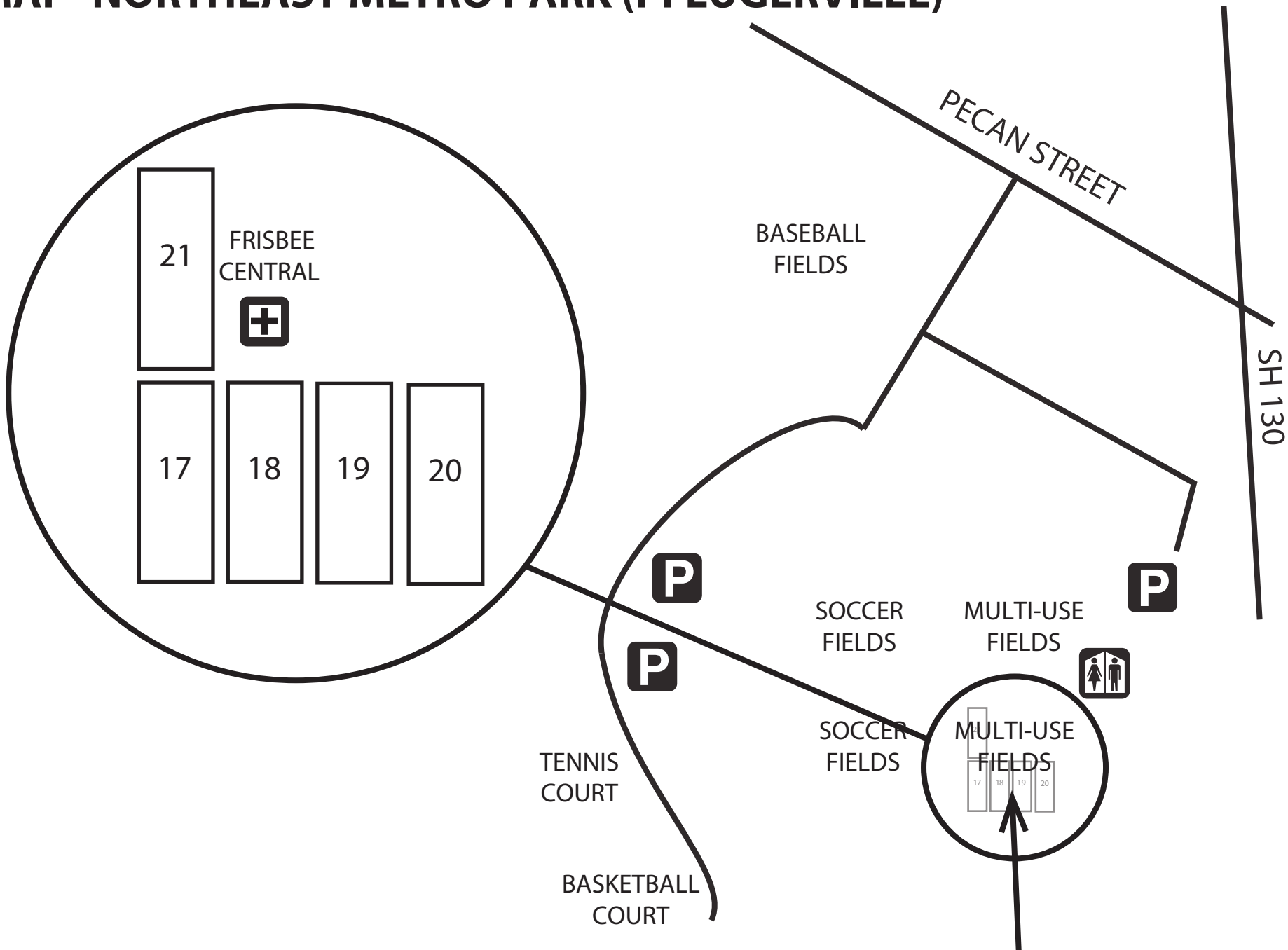

WE ARE USING THE FIELDS IN THISPART OF THE COMPLEX-
LABELED 16, 17, 18 ACCORDING TO COMPLEX SIGNAGE

WOMEN'S COLLEGE CENTEX 2012 SATURDAY POOL PLAY

Please report your scores AND spirit scores
via text message to (415) 215-0903.

DIVISION I

Pool A						
(0-0) A1 <u>North Carolina</u>						
(0-0) A2 <u>Texas</u>						
(0-0) A3 <u>UCLA</u>						
(0-0) A4 <u>Central Florida</u>						
Sat	Fld	Game	Score	Fld	Game	Score
11:00	1	A1A3	-	4	A2A4	-
1:00	1	A1A4	-	4	A2A3	-
3:00	1	A1A2	-	4	A3A4	-

Pool B						
(0-0) B1 <u>California</u>						
(0-0) B2 <u>Michigan</u>						
(0-0) B3 <u>Stanford</u>						
(0-0) B4 <u>Washington University</u>						
Sat	Fld	Game	Score	Fld	Game	Score
11:00	2	B1B3	-	3	B2B4	-
1:00	2	B1B4	-	3	B2B3	-
3:00	2	B1B2	-	3	B3B4	-

Pool C						
(0-0) C1 <u>Iowa</u>						
(0-0) C2 <u>British Columbia</u>						
(0-0) C3 <u>Wisconsin</u>						
(0-0) C4 <u>Northwestern</u>						
Sat	Fld	Game	Score	Fld	Game	Score
11:00	5	C1C3	-	6	C2C4	-
1:00	5	C1C4	-	6	C2C3	-
3:00	5	C1C2	-	6	C3C4	-

Pool D						
(0-0) D1 <u>Iowa State</u>						
(0-0) D2 <u>California-Santa Barbara</u>						
(0-0) D3 <u>Virginia</u>						
(0-0) D4 <u>Carleton College</u>						
Sat	Fld	Game	Score	Fld	Game	Score
11:00	7	D1D3	-	8	D2D4	-
1:00	7	D1D4	-	8	D2D3	-
3:00	7	D1D2	-	8	D3D4	-

GAMES TO 15- IM FIELDS



QR code for reporting scores via SRT

WOMEN'S COLLEGE CENTEX 2012 SATURDAY POOL PLAY (CONTINUED)

Please report your scores AND spirit scores
via text message to (415) 215-0903.

DIVISION II

Pool E						
(0-0) E1 <u>Rice</u>						
(0-0) E2 <u>California-San Diego</u>						
(0-0) E3 <u>Wisconsin-Eau Claire</u>						
(0-0) E4 <u>MIT</u>						
Sat	Fld	Game	Score	Fld	Game	Score
11:00	9	E1E3	-	10	E2E4	-
1:00	9	E1E4	-	10	E2E3	-
3:00	9	E1E2	-	10	E3E4	-

Pool F						
(0-0) F1 <u>Dartmouth</u>						
(0-0) F2 <u>Colorado</u>						
(0-0) F3 <u>Texas A & M</u>						
(0-0) F4 <u>James Madison</u>						
Sat	Fld	Game	Score	Fld	Game	Score
11:00	11	F1F3	-	12	F2F4	-
1:00	11	F1F4	-	12	F2F3	-
3:00	11	F1F2	-	12	F3F4	-

Pool G						
(0-0) G1 <u>Colorado College</u>						
(0-0) G2 <u>Northeastern</u>						
(0-0) G3 <u>Southern California</u>						
(0-0) G4 <u>Swarthmore</u>						
Sat	Fld	Game	Score	Fld	Game	Score
11:00	13	G1G3	-	14	G2G4	-
1:00	13	G1G4	-	14	G2G3	-
3:00	13	G1G2	-	14	G3G4	-

Pool H						
(0-0) H1 <u>Georgia</u>						
(0-0) H2 <u>Maryland</u>						
(0-0) H3 <u>Illinois</u>						
(0-0) H4 <u>Claremont</u>						
Sat	Fld	Game	Score	Fld	Game	Score
11:00	15	H1H3	-	16	H2H4	-
1:00	15	H1H4	-	16	H2H3	-
3:00	15	H1H2	-	16	H3H4	-

GAMES TO 15- IM FIELDS



QR code for reporting scores via SRT

WOMEN'S COLLEGE CENTEX 2012 SATURDAY POOL PLAY (CONTINUED)

Please report your scores AND spirit scores via text message to (415) 215-0903.

DIVISION III

Pool I						
(0-0) I1 <u>Kansas</u>						
(0-0) I2 <u>Texas State</u>						
(0-0) I3 <u>Texas-B</u>						
(0-0) I4 <u>Northwestern-B</u>						
Sat	Fld	Game	Score	Fld	Game	Score
10:45	17	I1I3	-	18	I2I4	-
12:45	17	I1I4	-	18	I2I3	-
2:45	17	I1I2	-	18	I3I4	-

Pool J			
(0-0) J1 <u>South Florida</u>			
(0-0) J2 <u>North Texas</u>			
(0-0) J3 <u>Texas-Arlington</u>			
Sat	Fld	Game	Score
8:45	19	J1J3	-
10:45	19	J2J3	-
12:45	19	J1J2	-

Pool K			
(0-0) K1 <u>Oklahoma</u>			
(0-0) K2 <u>Pacific Lutheran</u>			
(0-0) K3 <u>Sam Houston</u>			
Sat	Fld	Game	Score
8:45	20	K1K3	-
10:45	20	K1K2	-
12:45	20	K2K3	-

Re-seed before Crossover Games.

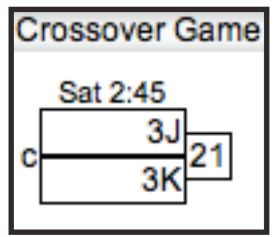
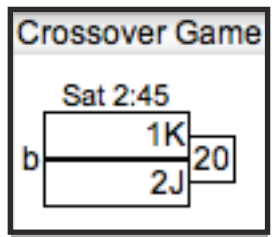
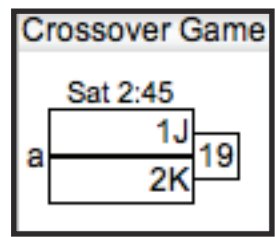

The Top 2 finishers in Pool I and Wa and Wb will have additional games at the IM Fields.

GAMES TO 15- NORTHEAST METRO PARK



QR code for reporting scores via SRT

WOMEN'S COLLEGE CENTEX 2012 SATURDAY CROSSOVER GAMES AND SUNDAY BRACKET PLAY

Please report your scores AND spirit scores
via text message to (415) 215-0903.

Re-seed before Crossover Games.

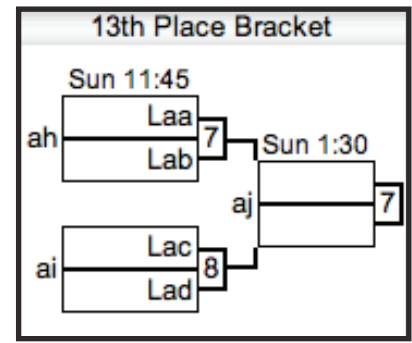
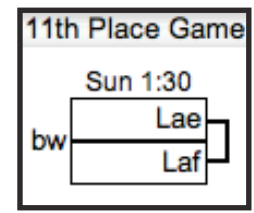
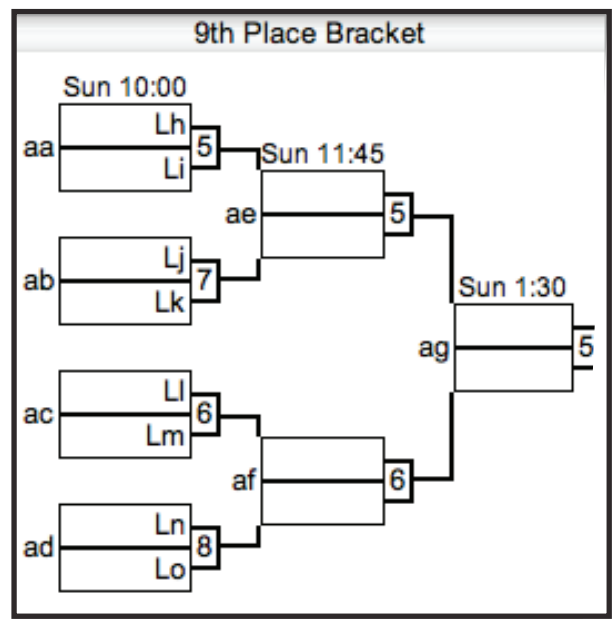
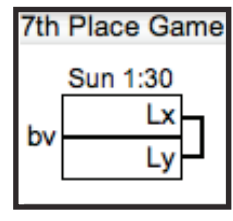
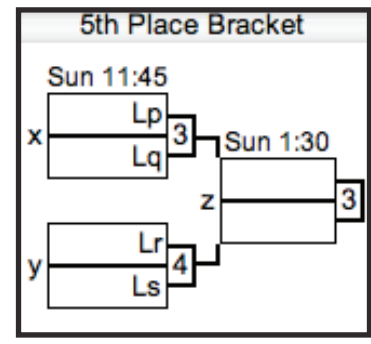
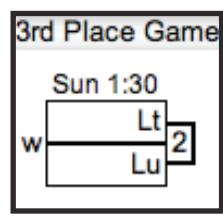
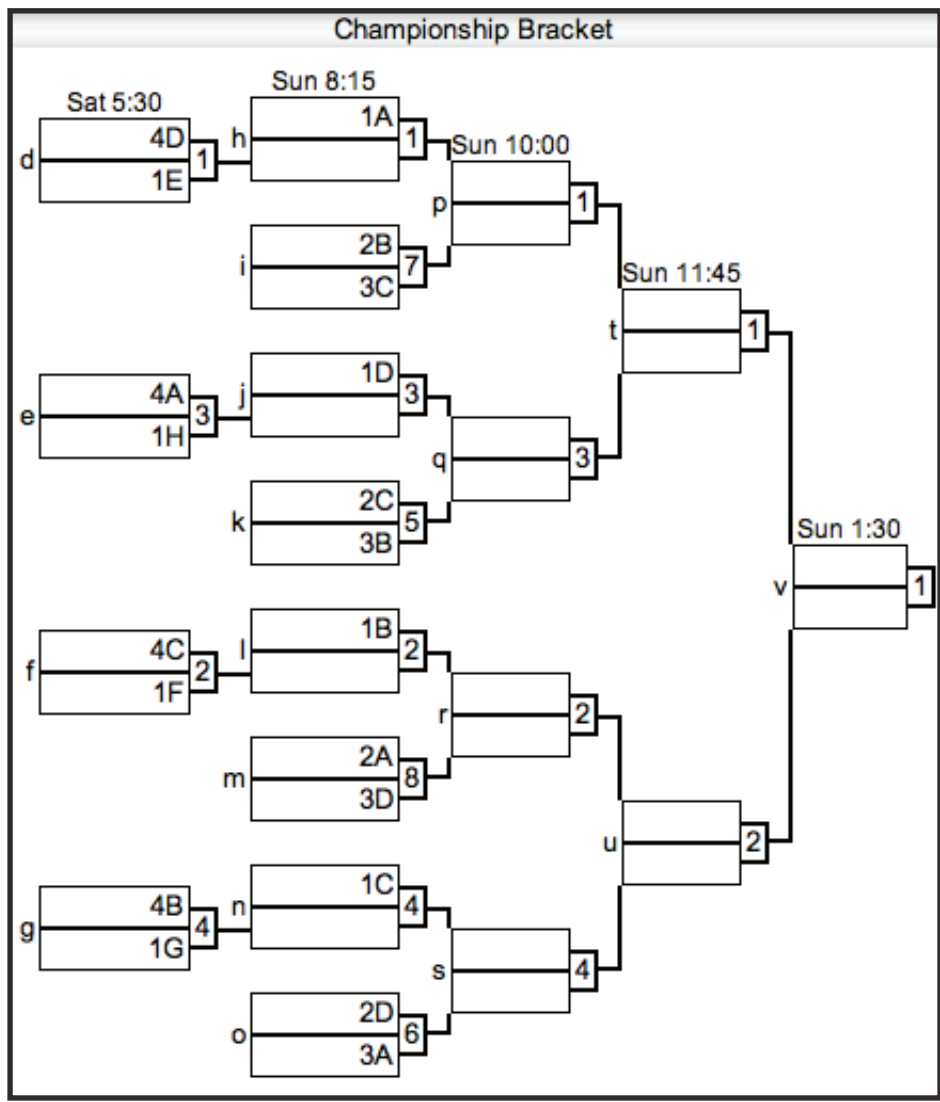

QR code for reporting scores via SRT

GAMES TO 15- IM FIELDS

WOMEN'S COLLEGE CENTEX 2012 SATURDAY CROSSOVER GAMES AND SUNDAY BRACKET PLAY (CONTINUED)

Please report your scores AND spirit scores via text message to (415) 215-0903.

Re-seed before Crossover Games.

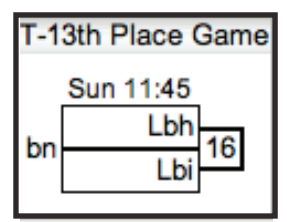
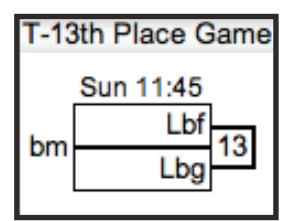
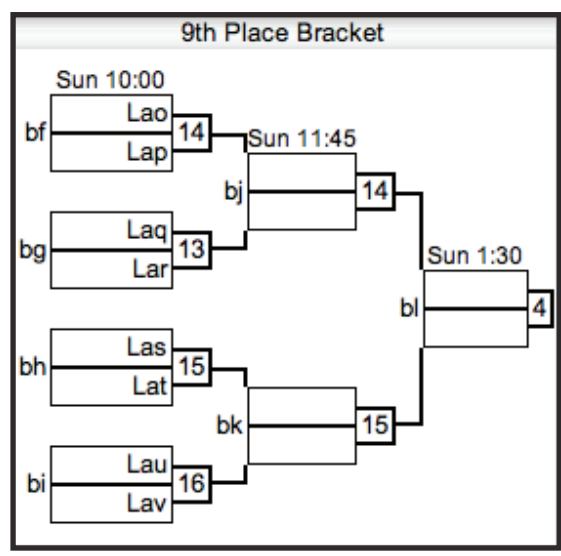
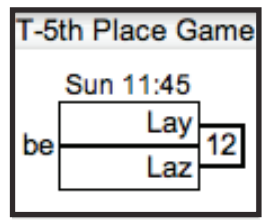
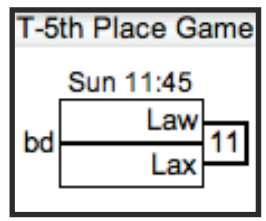
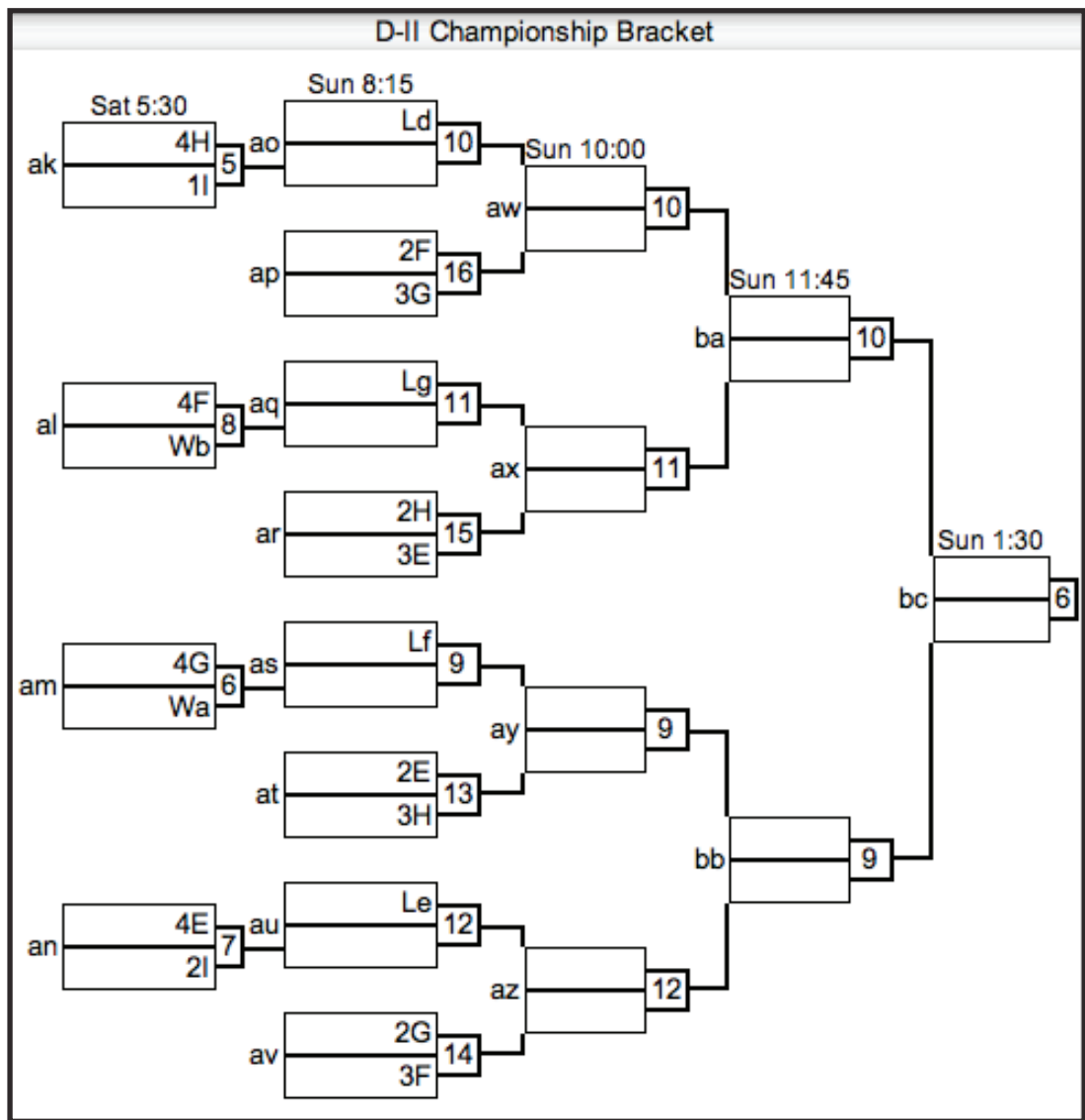

QR code for reporting scores via SRT

GAMES TO 15- IM FIELDS

WOMEN'S COLLEGE CENTEX 2012 SUNDAY BRACKET PLAY (CONTINUED)

Please report your scores AND spirit scores via text message to (415) 215-0903.

Re-seed before Bracket Play.

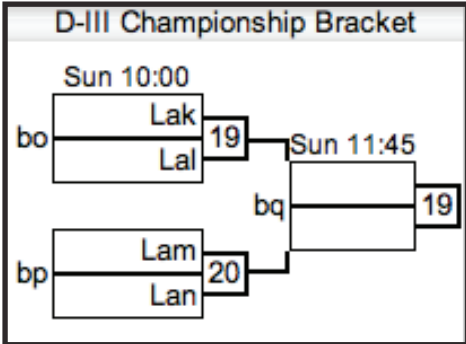

Pool L

(0-0) L12K
(0-0) L23J
(0-0) L34I

Sun	Fld	Game	Score
8:15	17	L1L3	-
10:00	17	L2L3	-
11:45	17	L1L2	-

Pool M

(0-0) M12J
(0-0) M23I
(0-0) M33K

Sun	Fld	Game	Score
8:15	18	M1M3	-
10:00	18	M2M3	-
11:45	18	M1M2	-

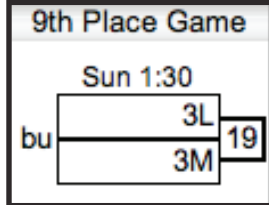
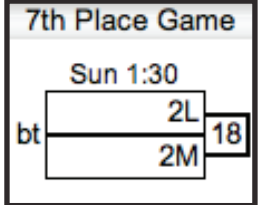
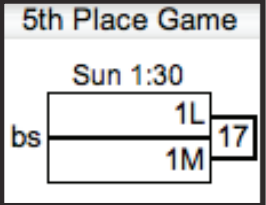

QR code for reporting scores via SRT

WOMEN'S COLLEGE CENTEX 2012 INCLEMENT WEATHER PLAN / BACKUP FIELD MAP

Lightning

The University of Texas IM Fields have an automatic lightning detector system that will sound warnings in the event that we need to evacuate the fields. If you hear the warning, please stop your game immediately and proceed to your cars. We will sound an all-clear signal when it is safe to return to the fields.

How to resume your game after a lightning delay:

1. If the delay was less than an hour and a half, the schedule will be adjusted to accommodate the continuance of the round being played. A quick captains' meeting will be held at Frisbee Central (see field map) to inform teams of the new schedule. Please send a team representative to Frisbee Central after you have been notified that the danger has passed.

2. If the delay is longer than an hour and a half and/or in the case of multiple lightning delays during a day, we will reassess the situation and determine a new schedule at the captains' meeting.

Our #1 concern is your safety, so please follow any directions from the TDs and other tournament staff.

Rain

In the event of the closure of the University of Texas IM Fields due to rain, we will be moving the tournament to our backup location. We reserve the right to alter the schedule as necessary to accommodate the conditions. This will likely involve the cancellation of crossover games and shortened rounds.

If Sunday games are moved to the backup field site, rounds will end no later than 3:45 in order to enable people to make Sunday night flights.

Please check in at Frisbee Central for updated field assignments.

For inclement weather updates, follow:



@wultimate

WOMEN'S COLLEGE CENTEX 2012

DIRECTIONS TO HOSPITAL

DIRECTIONS TO HOSPITAL
(DIVISION III FIELD SITE)



Directions from: Northeast Metro Park (Pflugerville)

1. Head southeast toward E Pecan St / Pflugerville East Rd (197 ft)
2. Turn left onto E Pecan St / Pflugerville East Rd. Continue to follow E Pecan St (3.5 mi)
3. Turn right onto Yellow Sage St. Destination will be on right. (0.2 mi)

Seton Pflugerville Healthcare Center
200 Heatherwilde Blvd
Pflugerville, TX 78660
(512) 324-5350

WOMEN'S COLLEGE CENTEX 2012

SPONSORS

We would like to thank all of our sponsors for supporting Texas Women's Ultimate and Women's College Centex. This event would not be possible without their generous donations. Thank you for everything you do for women's ultimate and for your local communities!

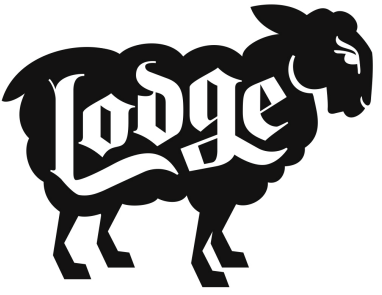

OFFICIAL SPONSOR



Austin's Pizza
austinspizza.com | 795.8888

WOMEN'S COLLEGE CENTEX 2012 ACKNOWLEDGMENTS

More work happens behind the scenes for this tournament than anyone can fully appreciate. Here is some special recognition for the people who have made this tournament possible:

- **YOU**, the players, for supporting our tournament
- The **Austin ultimate community** for housing teams
- The **Austin business community** for their generous sponsorships
- **Adriana Withers (VC Ultimate)** for her commitment to the growth and development of women's ultimate
- **Tina Woodings (UPLA President / Texas Ultimate alum)** for having the vision to make Centex happen
- **Ultimate Players League of Austin (UPLA)** for all of their wisdom and endless help with logistics
- **Chad Larson and Iram "J" Leon** for their special role in helping organizing fields and travel deals
- **Janel Venzant (Centex Board Chair)** for leading the Texas Ultimate program both on and off the field
- **Julie Paik, Darbi Donaldson, Naomi Trang, Vicky Wu, Libby Cravens, Diana Charrier, and Sharon Tsao** for their hours of hard work, ideas, and energy
- **Grace Kao (Texas Ultimate alum)** for designing the logo and merchandise
- **Hayley Manning (Texas Ultimate alum)** for her continued role in the growth and development of this tournament
- **Mike Depinet** for designing the Centex smartphone app
- **Hutton Supancic and Matthew Block** for serving as our event photographers

Take a moment and thank these people when you see them; they are the backbone of this tournament.

- Michelle

WITHOUT LIMITS



Women's Ultimate. Community. Competition. Empowerment. Without Limits.

Website: <http://www.withoutlimitsultimate.com>

Email: contactus@withoutlimitsultimate.com

Facebook: <http://www.facebook.com/WithoutLimitsUltimate>

Twitter: <http://www.twitter.com/wlultimate>

Spring 2012 Tournaments and Clinics

January 21-22: Midwest Captaining 101 Clinic (Grinnell, IA)

January 28: Houston Anti Freeze Skills Clinic (Houston, TX)

February 4-5: QCTU Qualifier + HS / College Skills Clinic (Chapel Hill, NC)

February 11: Cupid's Booty Hunt Skills Clinic (Tampa, FL)

February 11-12: Queen City Tune-Up (Charlotte, NC)

March 3-4: Midwest Throwdown + College Skills Clinic (St. Louis, MO)

March 10-11: Music City Mash-Up + HS / College Skills Clinic (Nashville, TN)

March 17-18: Virginia is for Layouts + Roundup Division + College Skills Clinic (Axton, VA)

March 24-25: Women's College Centex + Mixer + Women's Leadership Forum + Guest Coaching Program (Austin, TX)

March 31-April 1: Keystone Classic + HS / College Skills Clinic (Manheim, PA)

April 15: Women's Ultimate Skills Clinic (Toronto)

WITHOUT LIMITS



Women's Ultimate. Community. Competition. Empowerment. Without Limits.

Want more this summer and fall?

Announcing...

New to the Without Limits family!

Aug 25-26: Heavyweights (Rockford, IL)

Club Women's

Club Open

Club Mixed

Back by popular demand!

Sept TBA: Virginia Fusion (Axton, VA)

Club Women's

College Women's

For more information: <http://withoutlimitsultimate.com/projects>

WOMEN'S COLLEGE CENTEX 2012 SUBSTANCE POLICY

March 24, 2012

Dear Team,

Texas Women's Ultimate would like to welcome you to the University of Texas IM Fields. We are excited to bring teams from around North America to the most competitive tournament of the women's spring college season. Please be aware that we are not allowing any tobacco, alcohol, or illegal substances at the facilities for the duration of the weekend.

- We will check field bags and coolers to ensure that these substances are not found.
- If they are found, they will be confiscated. Your entire team will be asked to leave the fields immediately and will be banned from the fields for the remainder of the weekend.

Thank you for your cooperation. By adhering to these policies, you are guaranteeing that we will be allowed to host future events at the University of Texas IM Fields.

Sincerely,
Texas Women's Ultimate

As the leader of my team, I acknowledge that I have received the letter stating the substance policy along with its consequences. By signing this, I understand the terms and agree to abide by them. I also acknowledge that I have clearly communicated this policy to my teammates.

Signature: _____
Printed Name: _____
Team: _____
Date: _____